

© International Baccalaureate Organization 2022

All rights reserved. No part of this product may be reproduced in any form or by any electronic or mechanical means, including information storage and retrieval systems, without the prior written permission from the IB. Additionally, the license tied with this product prohibits use of any selected files or extracts from this product. Use by third parties, including but not limited to publishers, private teachers, tutoring or study services, preparatory schools, vendors operating curriculum mapping services or teacher resource digital platforms and app developers, whether fee-covered or not, is prohibited and is a criminal offense.

More information on how to request written permission in the form of a license can be obtained from <https://ibo.org/become-an-ib-school/ib-publishing/licensing/applying-for-a-license/>.

© Organisation du Baccalauréat International 2022

Tous droits réservés. Aucune partie de ce produit ne peut être reproduite sous quelque forme ni par quelque moyen que ce soit, électronique ou mécanique, y compris des systèmes de stockage et de récupération d'informations, sans l'autorisation écrite préalable de l'IB. De plus, la licence associée à ce produit interdit toute utilisation de tout fichier ou extrait sélectionné dans ce produit. L'utilisation par des tiers, y compris, sans toutefois s'y limiter, des éditeurs, des professeurs particuliers, des services de tutorat ou d'aide aux études, des établissements de préparation à l'enseignement supérieur, des fournisseurs de services de planification des programmes d'études, des gestionnaires de plateformes pédagogiques en ligne, et des développeurs d'applications, moyennant paiement ou non, est interdite et constitue une infraction pénale.

Pour plus d'informations sur la procédure à suivre pour obtenir une autorisation écrite sous la forme d'une licence, rendez-vous à l'adresse <https://ibo.org/become-an-ib-school/ib-publishing/licensing/applying-for-a-license/>.

© Organización del Bachillerato Internacional, 2022

Todos los derechos reservados. No se podrá reproducir ninguna parte de este producto de ninguna forma ni por ningún medio electrónico o mecánico, incluidos los sistemas de almacenamiento y recuperación de información, sin la previa autorización por escrito del IB. Además, la licencia vinculada a este producto prohíbe el uso de todo archivo o fragmento seleccionado de este producto. El uso por parte de terceros —lo que incluye, a título enunciativo, editoriales, profesores particulares, servicios de apoyo académico o ayuda para el estudio, colegios preparatorios, desarrolladores de aplicaciones y entidades que presten servicios de planificación curricular u ofrezcan recursos para docentes mediante plataformas digitales—, ya sea incluido en tasas o no, está prohibido y constituye un delito.

En este enlace encontrará más información sobre cómo solicitar una autorización por escrito en forma de licencia: <https://ibo.org/become-an-ib-school/ib-publishing/licensing/applying-for-a-license/>.

Physics
Higher level
Paper 2

Thursday 3 November 2022 (afternoon)

Candidate session number

2 hours 15 minutes

--	--	--	--	--	--	--	--	--	--

Instructions to candidates

- Write your session number in the boxes above.
- Do not open this examination paper until instructed to do so.
- Answer all questions.
- Answers must be written within the answer boxes provided.
- A calculator is required for this paper.
- A clean copy of the **physics data booklet** is required for this paper.
- The maximum mark for this examination paper is **[90 marks]**.



Answer **all** questions. Answers must be written within the answer boxes provided.

1. A raindrop falls vertically from rest.

(a) State the initial acceleration of the raindrop.

[1]

.....
.....

The graph shows how the speed of the raindrop varies with time t .

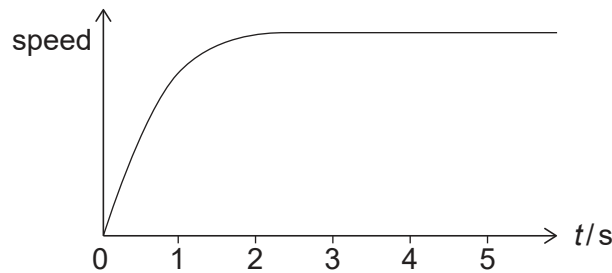

(b) Explain, by reference to the vertical forces, how the raindrop reaches a constant speed.

[3]

.....
.....
.....
.....
.....
.....

(This question continues on the following page)



(Question 1 continued)

(c) During the first 3.0 s of motion, the raindrop falls a distance of 21 m and reaches a speed of 9.0 m s^{-1} . The mass of the raindrop is 34 mg. The temperature of the raindrop does not change.

(i) Determine the energy transferred to the air during the first 3.0 s of motion. State your answer to an appropriate number of significant figures. [3]

.....
.....
.....
.....
.....
.....

(ii) Describe the energy change that takes place for $t > 3.0 \text{ s}$. [1]

.....
.....



28EP03

Turn over

2. A solar heating panel is placed on the roof of a house in order to heat water in a storage tank. The rest of the roof is covered with tiles.

(a) On a certain day, the intensity of the solar radiation that is incident perpendicular to the surface of the panel is 680 W m^{-2} .

The following data are available.

Mass of the water in the tank = 250 kg

Initial temperature of the water in the tank = 15°C

Specific heat capacity of water = $4200 \text{ J kg}^{-1} \text{ K}^{-1}$

Overall efficiency of the heating system = 0.30

Albedo of the roof tiles = 0.20

Emissivity of the roof tiles = 0.97

(i) Determine the minimum area of the solar heating panel required to increase the temperature of all the water in the tank to 30°C during a time of 1.0 hour. [3]

.....

.....

.....

.....

.....

.....

(ii) Estimate, in $^\circ\text{C}$, the temperature of the roof tiles. [3]

.....

.....

.....

.....

.....

.....

(This question continues on the following page)



(Question 2 continued)

- (b) There is an air space above the water in the storage tank with an opening to the atmosphere. Assume that air behaves like an ideal gas.

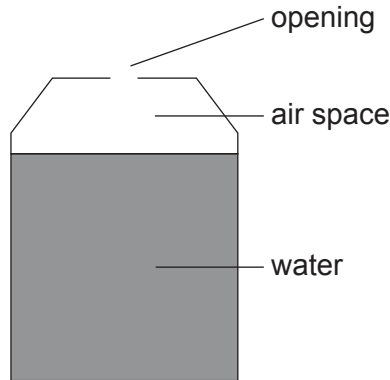

- (i) State **one** way in which a real gas differs from an ideal gas. [1]

.....

.....

The air space is always at constant atmospheric pressure and constant volume, as the water level is kept constant. The air-space temperature and water temperature are the same.

- (ii) The water is heated. Explain why the quantity of air in the storage tank decreases. [2]

.....

.....

.....

.....

- (c) Another method of harnessing solar energy involves the use of photovoltaic cells.

Outline **one** advantage of the output of a photovoltaic cell compared to the output of a solar heating panel. [2]

.....

.....

.....

.....



3. A string of length 0.80 m is fixed at both ends. The diagram shows a standing wave formed on the string. P and Q are two particles on the string.

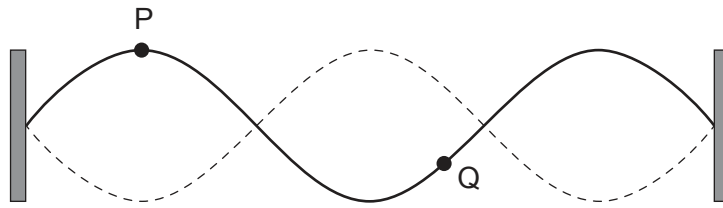

- (a) The variation with time t of the displacement of particle P is shown.

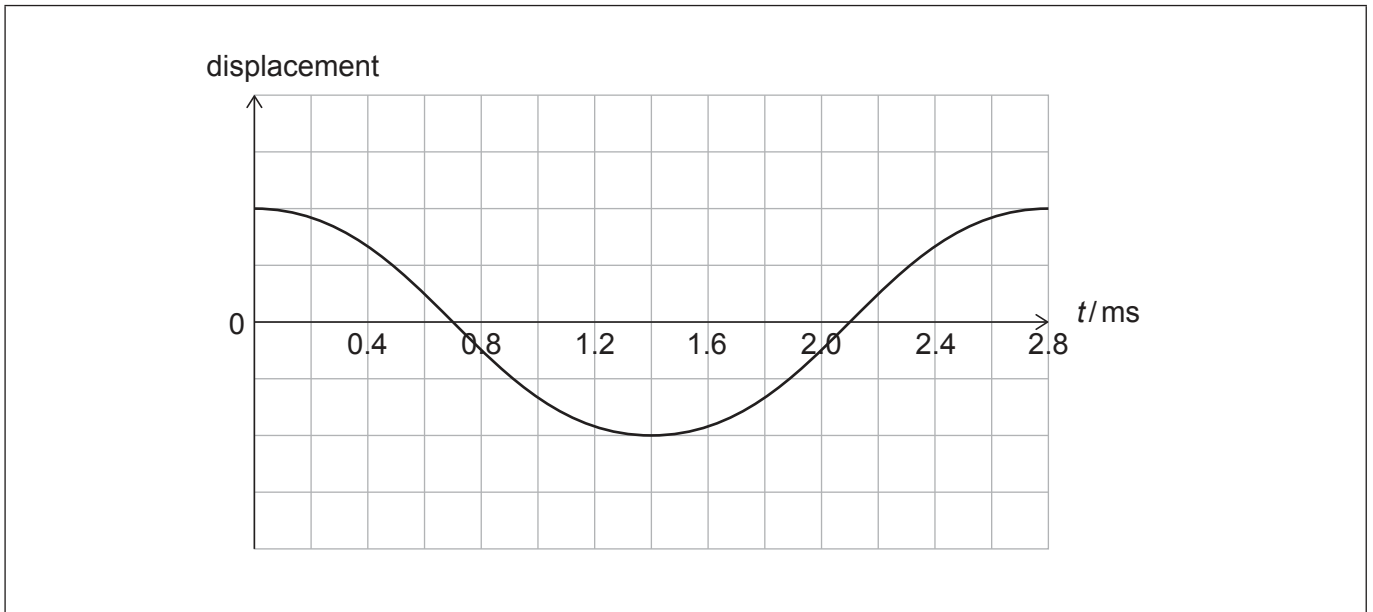

- (i) Draw, on the axes, a graph to show the variation with t of the displacement of particle Q. [2]
- (ii) Calculate the speed of waves on the string. [2]

.....

.....

.....

.....

(This question continues on the following page)



(Question 3 continued)

(b) It is suggested that the speed c of waves in the string is related to the tension force T in the string according to the equation $T = ac^2$, where a is a constant.

(i) Determine the fundamental SI unit for a . [2]

.....

.....

.....

.....

(ii) The tension force on the string is doubled. Describe the effect, if any, of this change on the frequency of the standing wave. [2]

.....

.....

.....

.....

(This question continues on page 9)



28EP07

Turn over

Please **do not** write on this page.

Answers written on this page
will not be marked.



28EP08

(Question 3 continued)

(c) The standing wave on the string creates a travelling sound wave in the surrounding air.

(i) Outline **one** difference between a standing wave and a travelling wave. [1]

.....
.....

The sound wave is incident on a surface of water. The wave makes an angle of 30° with the normal to the surface.

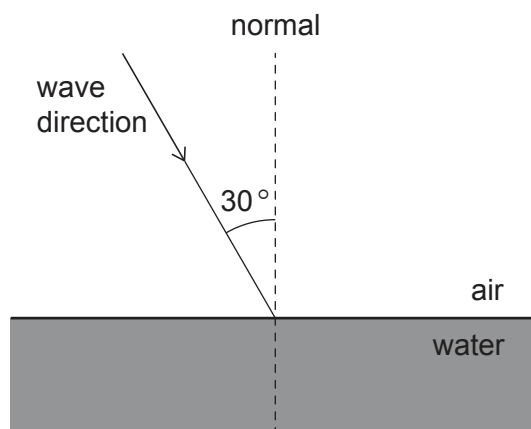

(ii) The speed of sound in air is 340 ms^{-1} and in water it is 1500 ms^{-1} .

Discuss whether the sound wave can enter the water. [2]

.....
.....
.....
.....



28EP09

Turn over

Please **do not** write on this page.

Answers written on this page
will not be marked.



28EP10

4. A mass is attached to one end of a rod and made to rotate with constant speed in a vertical circle.

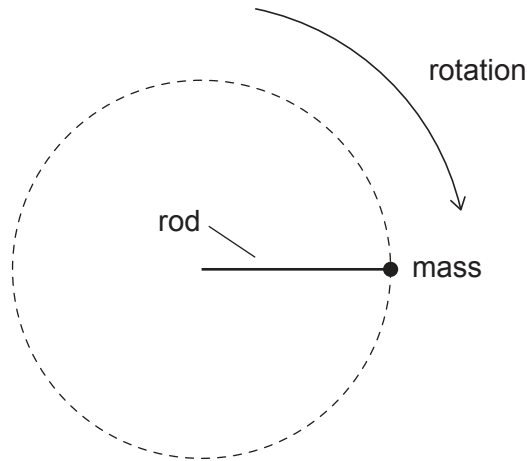

- (a) The scale diagram shows the weight W of the mass at an instant when the rod is horizontal.

Draw, on the scale diagram, an arrow to represent the force exerted on the mass by the rod.

[2]

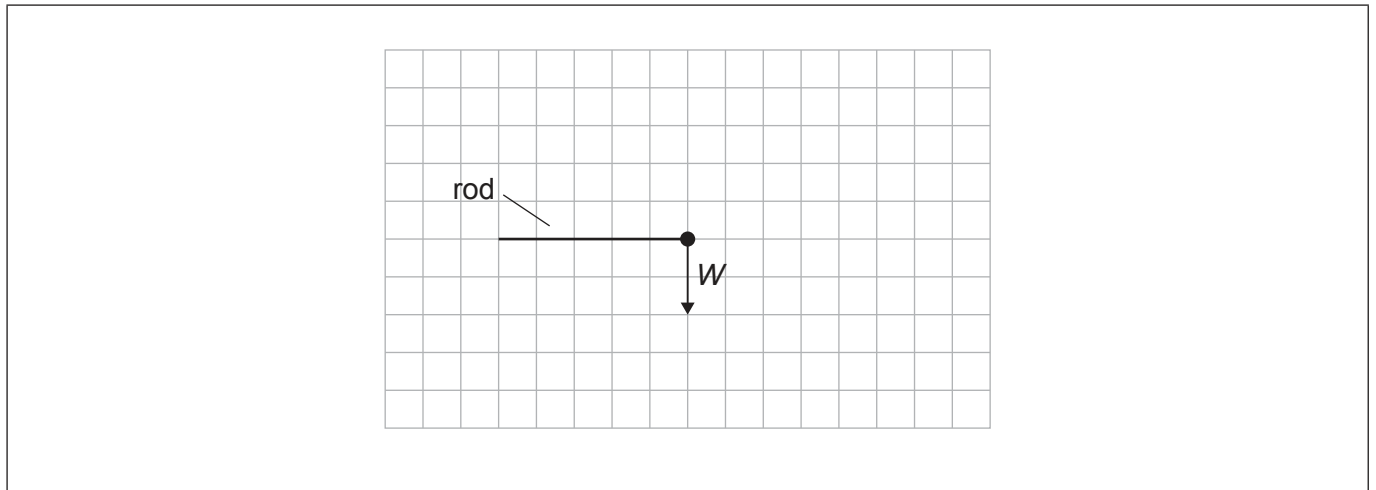

- (b) Explain why the magnitude of the force exerted on the mass by the rod is not constant. [3]

.....

.....

.....

.....

.....

.....



5. Resistor R is connected in a circuit with a cell that has internal resistance.

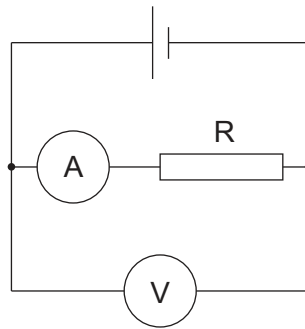

The ammeter and the voltmeter are ideal.

(a) State what is meant by an ideal voltmeter. [1]

.....
.....

(b) The resistance of R is $50.0\ \Omega$. The voltmeter reads 1.47 V .

(i) Calculate, in mA, the current in the resistor. [1]

.....
.....

Resistor R is replaced by another of resistance $10.0\ \Omega$. The ammeter now reads 139 mA .

(ii) Show that the internal resistance of the cell is about $0.7\ \Omega$. [2]

.....
.....
.....
.....

(This question continues on the following page)



(Question 5 continued)

(iii) Calculate the emf of the cell.

[2]

.....

.....

.....

.....

One of the connecting wires is placed in a magnetic field. The direction of the current in the wire is shown.

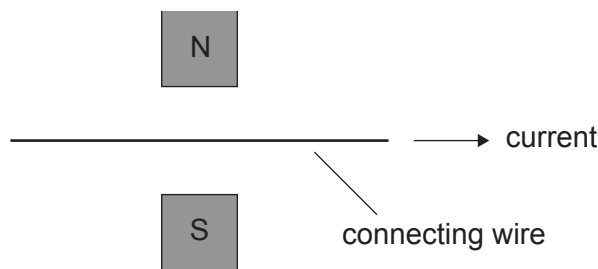

(c) (i) Explain, by reference to charge carriers in the wire, how the magnetic force on the wire arises.

[2]

.....

.....

.....

.....

(ii) Identify the direction of the magnetic force on the wire.

[1]

.....

.....



28EP13

Turn over

6. (a) Outline, by reference to nuclear binding energy, why the mass of a nucleus is less than the sum of the masses of its constituent nucleons. [2]

.....

.....

.....

.....

Polonium-210 (Po-210) decays by alpha emission into lead-206 (Pb-206).

The following data are available.

Nuclear mass of Po-210 = 209.93676 u

Nuclear mass of Pb-206 = 205.92945 u

Mass of the alpha particle = 4.00151 u

- (b) (i) Calculate, in MeV, the energy released in this decay. [2]

.....

.....

.....

.....

- (ii) The polonium nucleus was stationary before the decay.

Show, by reference to the momentum of the particles, that the kinetic energy of the alpha particle is much greater than the kinetic energy of the lead nucleus. [3]

.....

.....

.....

.....

.....

(This question continues on the following page)



(Question 6 continued)

- (iii) In the decay of polonium-210, alpha emissions can be accompanied by the emissions of gamma photons, all of the same wavelength of 1.54×10^{-12} m.

Discuss how this observation provides evidence for discrete nuclear energy levels. [3]

.....

.....

.....

.....

.....

.....

- (c) A sample contains 5.0 g of pure polonium-210. The decay constant of polonium-210 is $5.8 \times 10^{-8} \text{ s}^{-1}$. Lead-206 is stable.

Calculate the mass of lead-206 present in the sample after one year. [3]

.....

.....

.....

.....

.....

.....



7. A beam of coherent monochromatic light is incident normally on a single rectangular slit. The diffraction pattern is observed on a screen.

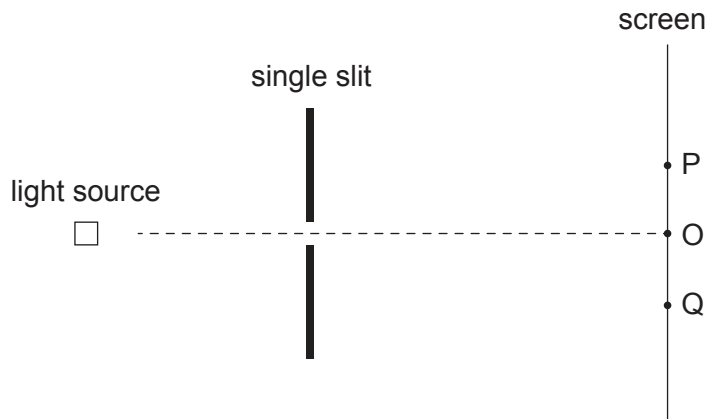

O is the point on the screen directly opposite the slit. P and Q are the first minima on either side of the central fringe of the diffraction pattern.

- (a) (i) The intensity of light at point O is I_0 . The distance OP is x .

Sketch, on the axes, a graph to show the variation of the intensity of light with distance from point O on the screen. Your graph should cover the distance range from 0 to $2x$.

[2]

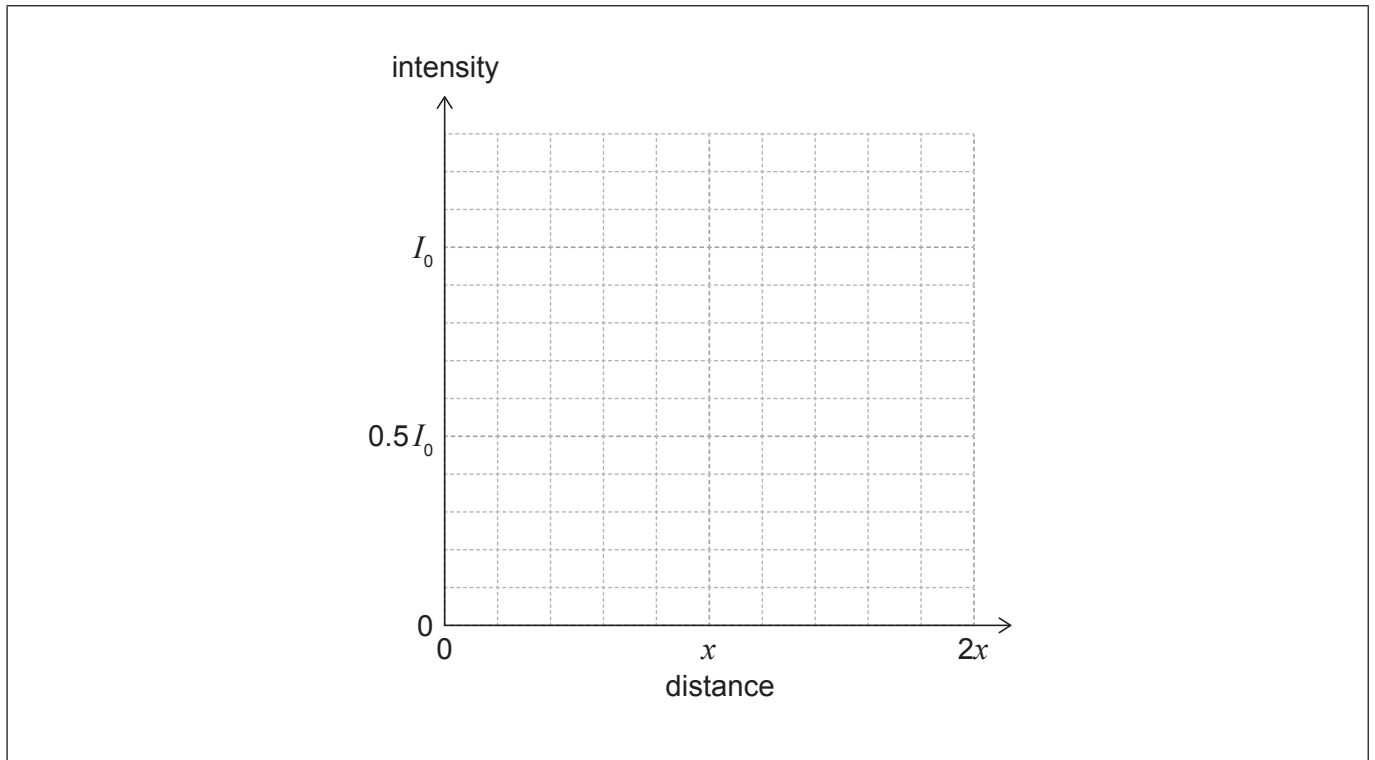

(This question continues on the following page)



(Question 7 continued)

- (ii) Early theories of light suggest that a geometrical shadow of the slit will be observed on the screen. Explain how the diffraction pattern formed on the screen provides evidence for the wave theory of light. [2]

.....

.....

.....

.....

- (iii) The following data are available.

Wavelength of light = 590 nm

Distance between the slit and the screen = 2.4 m

Width of the slit = 0.10 mm

Calculate distance PQ.

[2]

.....

.....

.....

.....

(This question continues on page 19)



Please **do not** write on this page.

Answers written on this page
will not be marked.



28EP18

(Question 7 continued)

- (b) The single slit is replaced by a double slit. The width of each slit in this arrangement is the same as the width of the single slit in (a).

Outline how the intensity variation observed between points P and Q will change. [2]

.....

.....

.....

.....

.....

- (c) The light source actually emits two wavelengths of light. The average wavelength is 590 nm and the difference between the two wavelengths is 0.60 nm.

A student attempts to resolve the wavelengths using a diffraction grating with 750 lines per mm. The incident beam is 2.0 mm wide.

Comment on whether this diffraction grating can resolve the wavelengths in the first-order spectrum. [3]

.....

.....

.....

.....

.....



8. (a) The diagram shows field lines for an electrostatic field. X and Y are two points on the same field line.

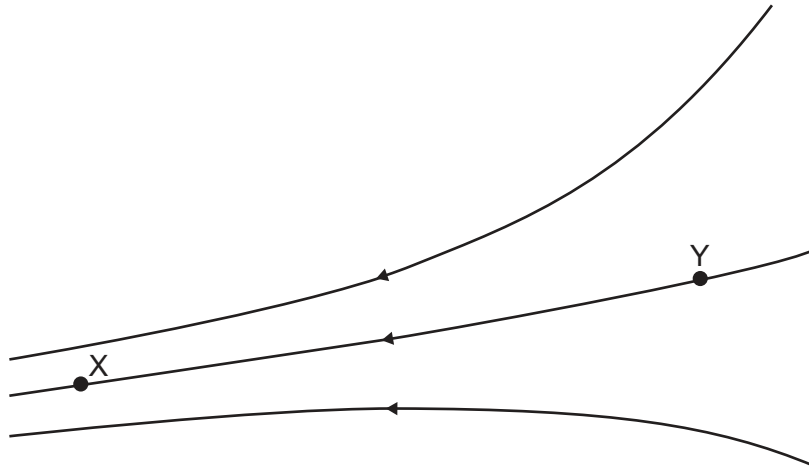

Outline which of the two points has the larger electric potential.

[2]

.....

.....

.....

.....

(This question continues on the following page)



(Question 8 continued)

(b) A satellite is launched from the surface of Earth into a circular orbit.

The following data are given.

Mass of the satellite = 8.0×10^2 kg

Height of the orbit above the surface of Earth = 5.0×10^5 m

Mass of Earth = 6.0×10^{24} kg

Radius of Earth = 6.4×10^6 m

(i) Show that the kinetic energy of the satellite in orbit is about 2×10^{10} J. [2]

.....
.....
.....
.....

(ii) Determine the minimum energy required to launch the satellite. Ignore the original kinetic energy of the satellite due to Earth's rotation. [2]

.....
.....
.....
.....



28EP21

Turn over

9. A parallel-plate capacitor of capacitance 1.5×10^{-10} F is made from two metal plates separated by an air gap of 1.0 mm. The capacitor is initially charged to a potential difference of 24 V.

(a) Calculate the energy stored in the capacitor. [1]

.....
.....

The charged capacitor is disconnected from the voltage supply and the separation between the plates is increased to 4.0 mm.

(b) (i) Explain the change, if any, to the potential difference between the plates. [2]

.....
.....
.....
.....

(ii) Determine the work required to increase the separation of the plates. [2]

.....
.....
.....
.....

(This question continues on the following page)



(Question 9 continued)

The capacitor is then discharged through a fixed resistor. The initial current in the resistor is I_0 and the time constant of the circuit is τ .

- (c) (i) Draw, on the axes, a graph to show the variation with time of the current in the resistor. [2]

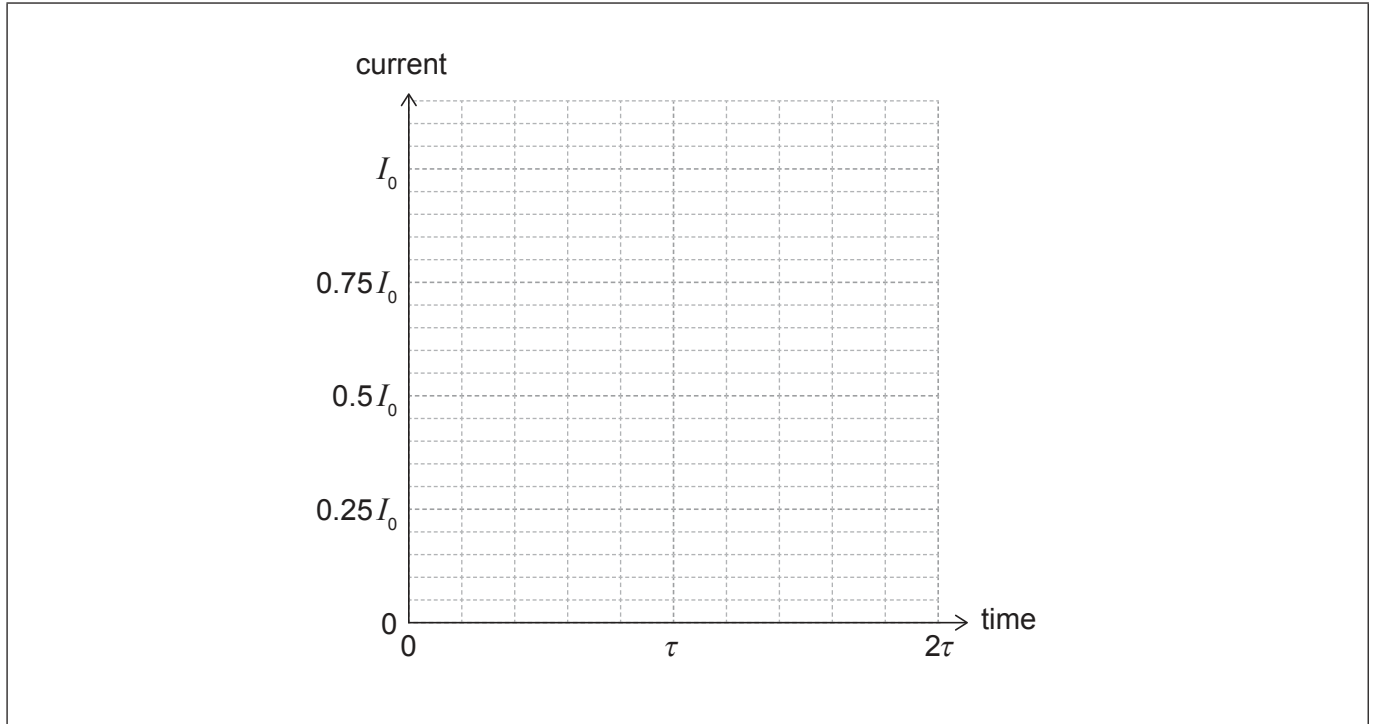

- (ii) A similar mathematical relationship can be used to model phenomena in other areas of physics.

State an example of such a phenomenon. [1]

.....
.....

(This question continues on page 25)



28EP23

Turn over

Please **do not** write on this page.

Answers written on this page
will not be marked.



28EP24

(Question 9 continued)

- (d) A diode bridge rectification circuit is often modified by adding a capacitor in parallel with the output (load) resistance.

Describe the reason for this modification.

[2]

.....

.....

.....

.....

.....

.....



28EP25

Turn over

10. The Feynman diagram shows a delta baryon (Δ) decaying into a neutron and particle X. The exchange particle involved in the decay is a gluon. Particle X has two constituent quarks.

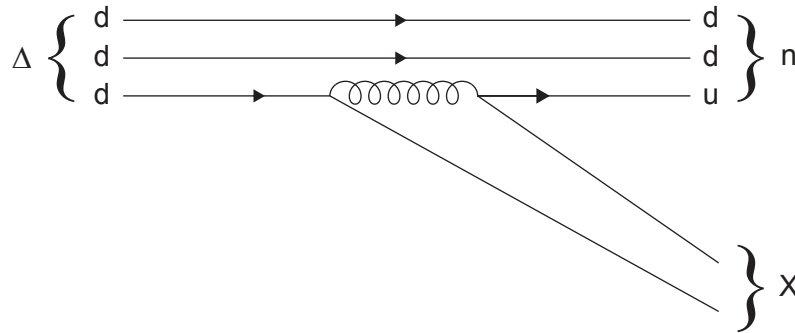

- (a) (i) Identify the fundamental force responsible for the decay. [1]

.....
.....

- (ii) Deduce, referring to one conservation law, that X is a quark-antiquark pair. [3]

.....
.....
.....
.....
.....
.....

(This question continues on the following page)



(Question 10 continued)

(b) The energy released in the decay is of the order of 10^8 eV.

Estimate, using the uncertainty principle, the mean lifetime of the delta baryon. [2]

.....

.....

.....

.....

References:

© International Baccalaureate Organization 2022



28EP27

Please **do not** write on this page.

Answers written on this page
will not be marked.



28EP28